

UMPC-2711

Mobility in Industrial Appliance

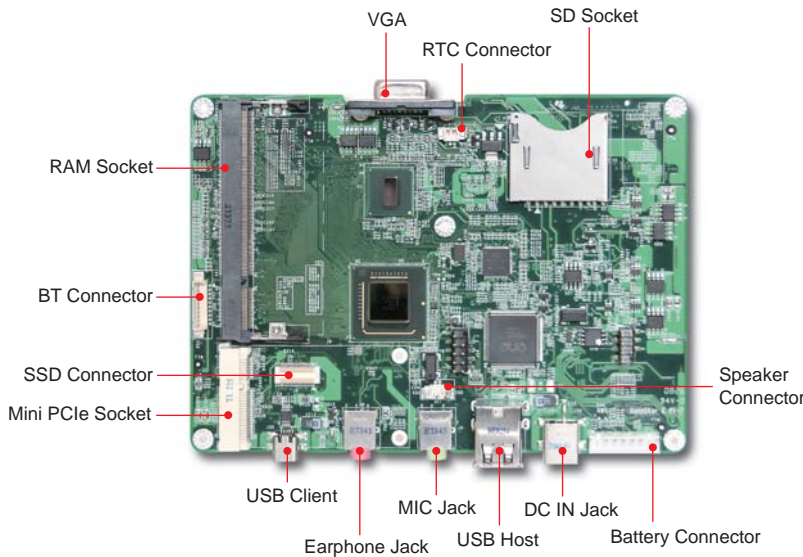

FEATURES

- 3.5" ECX form factor
- Ultra low power CPU Atom, Chipset US15W
- Up to 2GB DDR2 RAM
- 24-bits LVDS, expansion by SDVO, dual display
- PATA x 1, USB x 8 (host x 7, client x 1), PCIe x 2, SD x 1, HD Audio
- S3/S4 ACPI 3.0 compliant power options
- Auto CPU Throttling for thermal management
- Onboard EC for battery management, CIR
- Onboard battery charging circuit
- Hot Keys (backlight, volume, display...etc)
- Flash Utility for EC/BIOS update in DOS

The UMPC-2711 is a fanless and slim portable Atom™ board for point of sales (POS), point of care, point of service and point of inspection market, which leverages Intel®

cutting edge power saving technology to help critical tasks entering into mobile world.

SYSTEM

Processor	Intel® Atom™ Z530/1.6GHz Ultra low power processor, 512KB L2 cache, 400/533MHz FSB, TDP power ~2W
Chipset	Intel® SCH US15W (Premium 533MHz FSB, single chip)
System Memory	256M/512M/1G/2G DDR2 upgradeable; 400/533 MHz
Storage	- SST SSD, 2G/4GB/8G (optional) - 3 in 1 card (SD/SDIO/MMC)
Power	- DC-IN - DC 12V/4A, onboard DC2DC and charging circuit
Battery	- 2S1P/2 cells Li-ion rechargeable battery, 2200mAh - 2 hrs operation, 3 hrs charging. (SMBus, optional)
Expansion	Mini-PCIe x 1
Dimension	105(W) x 145(L) mm; 4.13"(W) x 5.70"(L)
Environment	Operation temperature: 0~60°C Storage temperature: -20~80°C Operation humidity: 5~95%, non-condensation

I/O

USB	USB 2.0 Host type "A" x 2 USB 2.0 Client type "B" x 1
Network	- 802.11 b/g (Mini-PCIe, optional) - Bluetooth 2.0 + EDR (USB, optional)
Audio	- 3.5mm headphone out - Microphone in

DISPLAY

Display	Onboard 1ch, 24bit LVDS Dual display: VGA & LVDS VGA out
----------------	--

USER INTERFACE

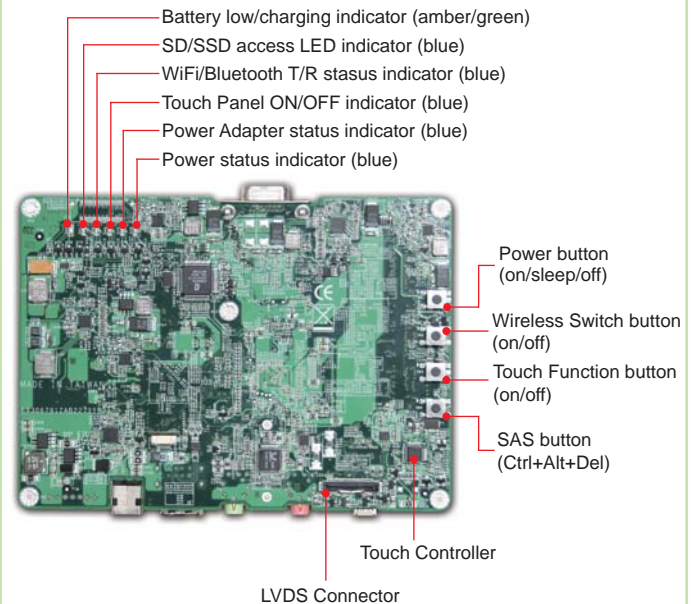

Portwell, Inc. (Headquarters)

4F, No. 186, Jian-Yi Rd., Chung-Ho City,
235 Taipei, Taiwan
Tel: +886-2-77318888
Fax: +886-2-82271109
E-mail: info@portwell.com.tw
http://www.portwell.com.tw

American Portwell

Fremont CA Tel: +1-510-403-3399
Norcross GA Tel: +1-678-969-9808
E-mail: info@portwell.com
http://www.portwell.com

Portwell Japan, Inc.

Tokyo Tel: +81-3-5298-8071
E-mail: info@portwell.co.jp
http://www.portwell.co.jp

Beijing Portwell

Beijing Tel: +86-10-82701616
Shanghai Tel: +86-21-3222-0505
Shenzhen Tel: +86-755-8621-7695
E-mail: info@portwell.com.cn
http://www.portwell.com.cn

Portwell-Laxsons India

Tel: +91-22-2685-9911
E-mail: info@portwellaxsons.com
http://www.portwellaxsons.com

Portwell, B.V.

Tel: +31-252-620790
E-mail: info@portwell.nl
http://www.portwell.nl

Portwell (UK) Ltd.

Tel: +44(0)1235-750760
E-mail: info@portwell.co.uk
http://www.portwell.co.uk